

specifications

The Digital Medical Gas Manifold shall be an Amico Alert-2 Liquid series. This manifold shall also include a five-year warranty which warrants a defect-free product.

The Manifold shall be a digital, fully automatic type and shall switch from "Bank In Use" to "Reserve" bank without fluctuation in the supply line pressure and without the need for external power. After the switch-over, the "Reserve" bank shall then become the "Bank in Use" and the "Bank in Use" shall become the "Reserve" bank. When change-over occurs, the 'Push to Test' button must be pressed to put board into "Ready" mode. The manifold shall have a microprocessor based digital display panel. The unit will be compact, measuring 16-3/4" high x 17" wide x 9" deep.

The control panel incorporates three large, red, illuminated LED displays for the Left Bank, the Right Bank and for the Supply Pressure. The control panel also uses six LED's, two Green for "Bank in Use", two Amber for "Bank Ready" and two Red for "Bank Empty".

PLEASE NOTE:

- The Manifold shall be equipped with a 3/4" outlet shut off valve. The valve comes complete with a 3/4" type "K" 6-3/4" [172 mm] long pipe extension and 1/8" port for an optional pressure switch.
- The header bars shall be equipped with emergency low pressure shutoff valves outside the cabinet to allow for emergency isolation of the header bars. The header bar shall incorporate integral check valves for each station. The manifold shall be equipped with limit switches and pressure transducers for indication and for operation of the fail-safe relay which transmits a remote Normally Closed signal to the master medical gas alarm.
- All manifold regulators, piping and control switching equipment shall be cleaned for oxygen service and installed inside the cabinet to minimize tampering with the regulators or switch settings.
- The Manifold cabinet is for general purpose use.

The Manifold shall include three pressure relief valves, one high pressure 250 psi [1,724 kPa] for all gases and two low pressure 75 psi [517 kPa] for Oxygen, Carbon Dioxide and Nitrous Oxide 65 psi [448 kPa]. Nitrogen has one high pressure relief valve set at 350 psi [2,413 kPa] and two low pressure at 200 psi [1,379 kPa].

The Manifold is UL Listed to U.S. and Canadian safety standards.

flow capacity

Depends on the amount of cylinder(s) and type of cylinder(s) used. For Oxygen the average flow per liquid container/cylinder is 350scfh. Flow capacity is increased with additional containers, for higher flow requirements an external vaporizer (supplied by others) is necessary. For the manifold, the maximum flow rate is approximately 1000scfh.



features

- ▶ Fully automatic self-contained shuttle-valve with no electrical power required for switching
- ▶ Input power 110 VAC to 240 VAC, 50 to 60 HZ
- ▶ Microprocessor based control panel incorporates 6 LED's and illuminated LED display readable even in poor lighting conditions
- ▶ Units of measure, switchable (psi/kPa/BAR)
- ▶ Two limit switches for positive indication of bank in use
- ▶ CGA gas specific header bar with integral check valves and cylinder pigtail assemblies (to be ordered separately)
- ▶ Dual line pressure regulators
- ▶ 3/4" isolation valve for supply line
- ▶ Third input for High-Pressure back-up reserve
- ▶ Manifold complies with CSA
- ▶ Interface to Amico AIMS system
- ▶ Economizer Circuit

project

Inch
[mm]

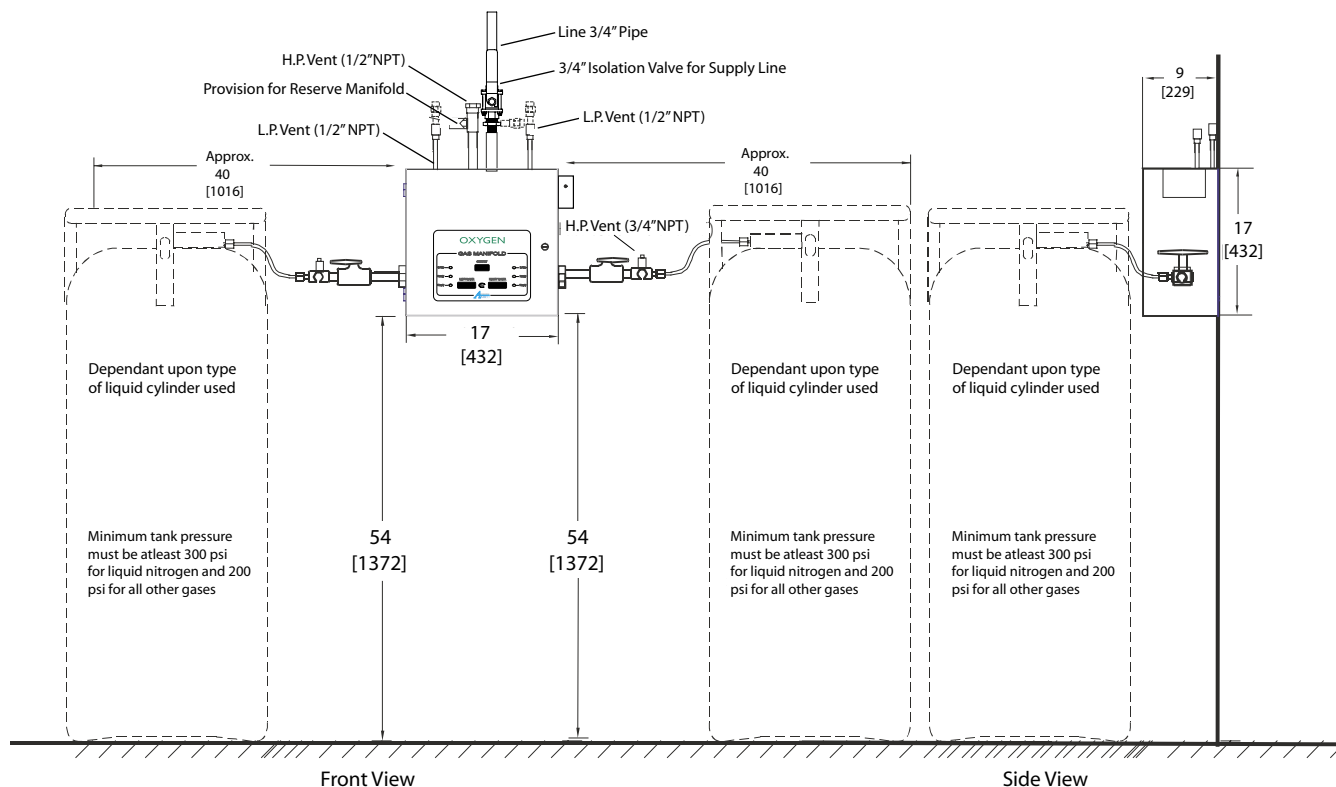

Manifold Cabinet:

model numbers

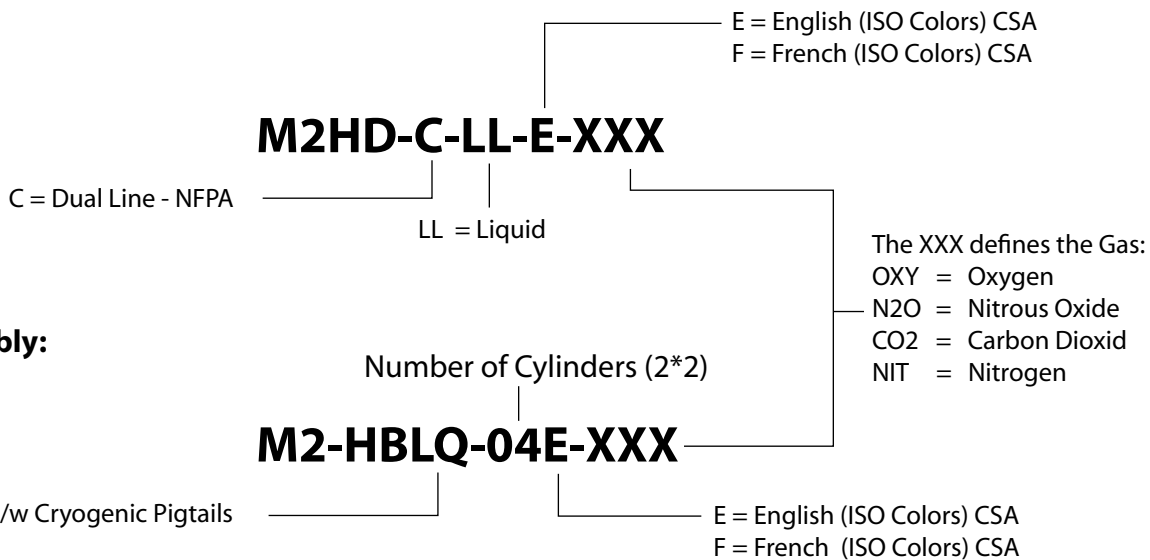

represented by: