

## specifications

The Economy Gas Manifold shall be an Amico Alert-2 series.

The Manifold shall be a semi-automatic type and shall require manual operation from "Reserve" to "In Use" bank without fluctuation in the supply line pressure and without the need for external power. After the manual switch-over, the "Reserve" bank shall then become the "Bank in Use" and the "Bank in Use" shall become the "Reserve" bank.

### PLEASE NOTE:

- The Manifold will automatically switch-over to the reserve bank when gas pressure depletes from the primary bank.
- A pressure switch controls remote alarms which indicate "In Use" to "Reserve" supply switch-over and when cylinder replacement is necessary. The switch is set to open when the operating line pressure drops to a pressure slightly above the secondary outlet pressure, just before switch-over occurs.
- The header bars shall be equipped with emergency high pressure shut-off valves to allow for emergency isolation of the header bars. The header bar shall incorporate integral check valves for each station (on the pigtails).
- All manifold regulators, piping and control switching equipment shall be cleaned for oxygen service.

The Manifold shall include two pressure relief valves, one high pressure at 225 psi [1,552 kPa] for all gases, and one low pressure 75 psi [517 kPa] for Oxygen, Air, Carbon Dioxide and Nitrous Oxide. Nitrogen will have two relief valves, one high pressure at 350 psi [2,413 kPa], and one low pressure at 225 psi [1,551 kPa].

The manifold complies with NFPA-99.

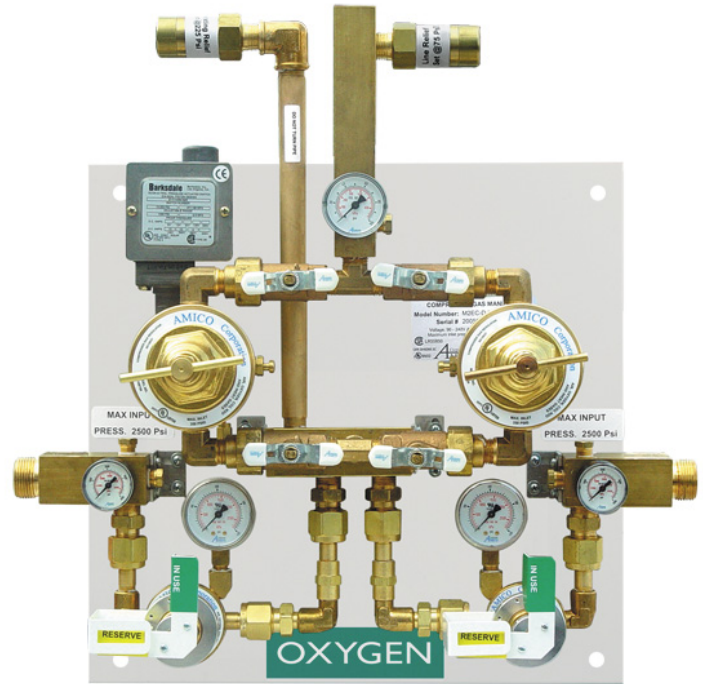

## flow capacity

Oxygen, Nitrous Oxide, Medical Air,  
Carbon Dioxide:

**4500 SCFH (1,179 L/min)**

Nitrogen:

**6000 SCFH (2,123 L/min)**

project

---



---



---

# Alert - 2 economy gas manifold - dual line regulator

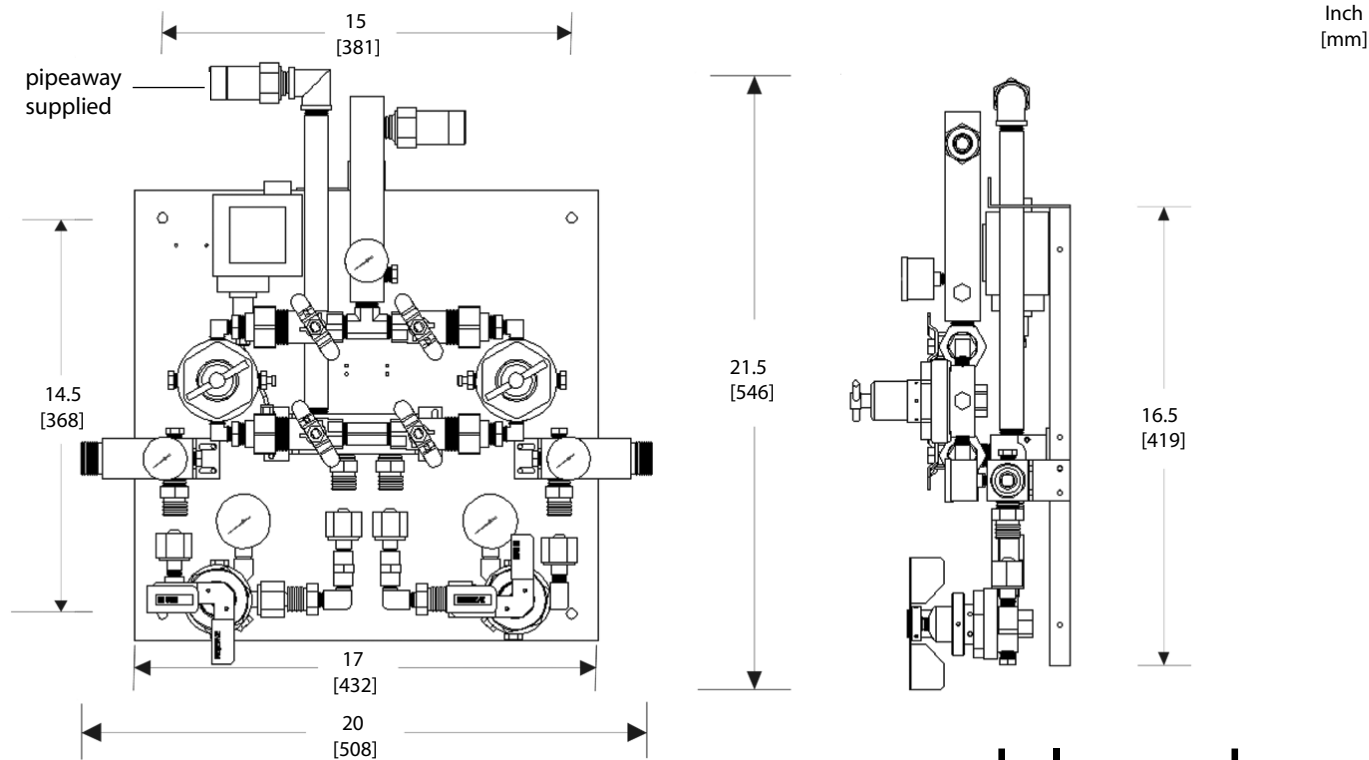

## model numbers

### Manifold Cabinet:

EC = Economy (4500 scfh)      U = English (NFPA)

**M2EC-D-HH-U-GAS**

D = Dual Line Regulators      Only available in High pressure

For proper model number replace the GAS with the following:

- OXY = Oxygen
- N2O = Nitrous Oxide
- NIT = Nitrogen
- AIR = Medical Air
- CO2 = Carbon Dioxide

### Header-bar Assembly:

Number of Cylinders (2\*2)

**M2-HBXC-04U-GAS**

TS = Straight c/w Stainless Pigtails  
 TC = Straight c/w Copper Pigtails  
 XS = Staggered c/w Stainless Pigtails  
 XC = Staggered c/w Copper Pigtails

U = English (NFPA)

### Remote Buzzer:

M2-REM-AL-NEMA

represented by: