

## NFPA 99 Compliant Duplex "Oil-Less" Claw Medical Vacuum Package 4 HP Horizontal Tank Mount

### Vacuum Package

- Fully compliant with the latest edition of NFPA 99
- Two oil-less rotary claw type vacuum pumps with inlet filter and isolation valve for each
- Two motors
- ASME coded horizontal air receiver with bypass and manual drain
- Duplex control panel with automatic lead/lag controls
- All components completely pre-piped and pre-wired to single point service connections
- Vibration isolation mountings
- Liquid tight conduit, fittings and junction boxes for all control and power wiring
- All interconnecting piping and wiring is completed and operationally tested prior to shipment

### Vacuum Pump

- Busch, rotary claw Mink MM Series pump
- Direct-driven through a shaft coupling
- Air-cooled
- End (ultimate) vacuum = 25.5" Hg (112.5 torr)
- Dry-running, with two claw-type, non-contacting rotors
- Sealing fluid not required
- Virtually maintenance-free operation
- Oil change required at approximately 20,000 operating hour intervals in the gearbox only
- Built-in, anti-suck-back valve mounted at the pump inlet and equipped with a 2 micron inlet filter for removal of particulates

### Vacuum Motor

- NEMA rated
- C-face
- TEFC
- 3600 RPM, with 1.15 service factor
- 208 or 230/460V 3-phase

### Intake Piping

- Vacuum pumps are connected to a common manifold and piped to a horizontal receiver
- Inlet check valve on each pump
- Inlet isolation valve on each pump
- Flexible connector between pump and manifold
- Flexible connectors for inlet and discharge and vibration pads included

### Vacuum Receiver

- Horizontal orientation with integrally mounted bypass and manual drain
- ASME Code stamped
- National Board Certified
- Rated for a minimum 200 PSIG design pressure
- Vacuum gauge
- Manual drain

### Control System

- Mounted and wired duplex control system
- NEMA 12 and U.L. labeled
- HMI (Human Machine Interface) – touch screen display
  - + vacuum display
  - + runtime display
  - + alarm history display
  - + maintenance schedule and history display
  - + service indicator
  - + replacement parts display
  - + battery backup for history display
- Automatic lead/lag sequencing
- Circuit breaker disconnects for each motor with external operators
- Full voltage motor starters with overload protection
- 120V control circuit transformers for each motor circuit
- Visual and audible reserve unit alarm with isolated contacts for remote alarm
- Hand-off-auto selector switches
- Automatic alternation of both vacuum pumps based on a first-on/first-off principle with provisions for simultaneous operation if required
- Automatic activation of reserve unit if required
- Visual and audible alarm indication for high discharge temperature shutdown with isolated contacts for remote alarm

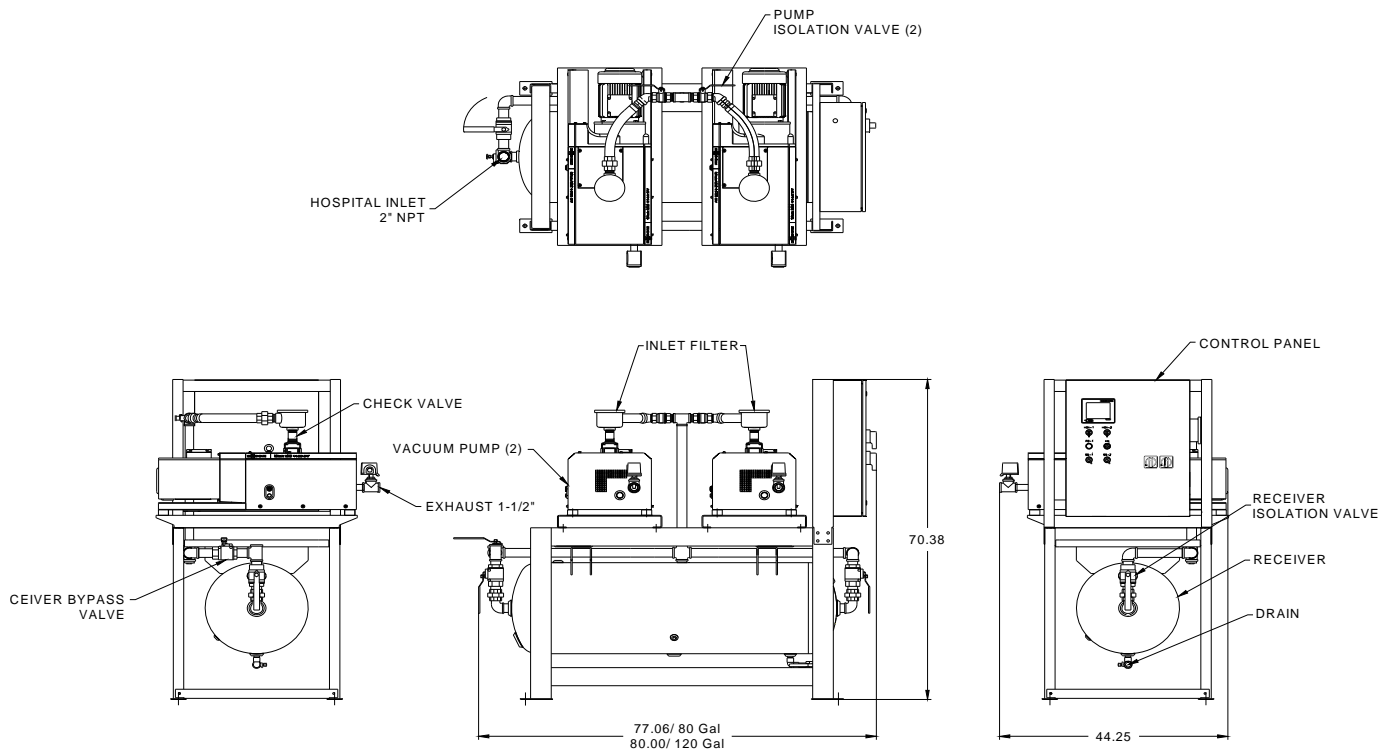

FOR A COMPLETE GENERAL ASSEMBLY DRAWING (#101-04-086) CONTACT PATTON'S MEDICAL

Duplex Claw Medical Vacuum Package Specifications <sup>1</sup>								
System Model No.	HP	Capacity @19" Hg <sup>2</sup>		Receiver Gal.	System FLA			Package Weight
		Pump (SCFM)	System (SCFM)		208V	230V	460V	
74-21-042A	4	29	29	80	29			1435
74-21-043A				120				1535
74-21-042B				80	25		1435	
74-21-043B				120			1535	
74-21-042C				80	13		1435	
74-21-043C				120			1535	

Notes:

<sup>1</sup> Normal Operating conditions at a maximum ambient of 105° F. Consult factory for higher ambient conditions.

<sup>2</sup> Capacities are shown as NFPA system capacities (reserve vacuum pump on standby).

**Statement of Warranty**

Patton's Medical warrants all Medical Vacuum packages, to be free of defects in material and workmanship under normal use for a period not to exceed thirty (30) months from date of shipment, or twenty-four (24) months from date of start-up.