

**Quadruplex Lubricated Rotary Vane Lab Vacuum Package 15 HP  
Vertical Base Mount with Automatic Purge Control**

**Vacuum Package**

- Four lubricated rotary vane type vacuum pumps with inlet filter and isolation valve for each
- Four motors
- ASME coded Vertical vacuum receiver with bypass and manual drain
- Quadruplex control panel with automatic lead/lag controls
- System designed for access through a standard 36" doorway
- All components completely pre-piped and pre-wired to single point service connections
- Liquid tight conduit, fittings and junction boxes for all control and power wiring
- All interconnecting piping and wiring is completed and operationally tested prior to shipment

**Vacuum Pump**

- Lubricated rotary vane pump
- Three non-metallic, non-asbestos vanes with minimum life of 30,000 hrs.
- Direct-driven through a shaft coupling
- Air-cooled
- End (ultimate) vacuum = 29.3" Hg
- Integral, fully recirculating oil supply
- Spin-on oil filter
- High discharge temperature switch
- Oil drain valve assembly with temperature gauge
- Integral oil separation system with three stage oil and smoke eliminators capable of removing 99.9+% of particles from the exhaust gas stream
- Built-in, anti-suck-back valve mounted at the pump inlet
- 2 micron inlet filter for removal of particulates
- Shipped with initial charge of pump fluid

**Vacuum Motor**

- NEMA rated
- C-face
- TEFC
- 208 or 230/460V 3-phase

**Vibration Isolation System**

- Vacuum and motor - fully isolated from the package base by means of a four-point, heavy duty, isolation system
- Minimum of 95% isolation efficiency
- Optional seismically restrained isolators at an additional cost

**Intake Piping**

- Vacuum pumps are connected to a common manifold and piped to a vertical receiver
- Inlet check valve on each pump
- Inlet isolation valve on each pump
- Flexible connectors between pumps and receiver
- Flexible connectors for discharge connections

**Vacuum Receiver**

- Vertical orientation with integrally mounted bypass and manual drain
- ASME Code stamped
- National Board Certified
- Rated for a minimum 200 PSIG design pressure
- Liquid level sight glass (**OPTION "V"**)
- Vacuum gauge
- Manual drain

**System Health**

- Monitoring and Trending of key components to provide notification of potential issue with the Health of the System
- Vacuum monitoring
- Current monitoring for each motor
- Ambient Temperature monitoring
- Trending of pumps running

**Control System**

- Mounted and wired quadruplex control system
- NEMA 12 and UL 508A labeled
- Automatic lead/lag sequencing
- Circuit breaker disconnects for each motor with external operators
- Full voltage motor starters with overload protection
- 120V control circuit transformers for each motor circuit
- Visual and audible reserve unit alarm with isolated contacts for remote alarm (**ability to turn OFF**)
- Hand-off-auto selector switches for reliable back-up
- Automatic alternation of compressors based on a first-on/first-off principle with provisions for simultaneous operation
- Automatic activation of reserve unit if required
- Visual and audible alarm indication for high discharge air temperature shutdown with isolated contacts for remote alarm
- SIGNAL 1™ – touch screen gateway

Standard Screen Displays

- |                        |  |
|------------------------|--|
| + Air level/Runtime    | + Replacement parts                    |
| + Alarm history        | + Troubleshooting guidelines           |
| + Service Indicator    | + Historical trending of system status |
| + Maintenance Schedule | + System Health                        |

- 7" Wide TFT Graphic Touch Screen with Motion Actuated Backlit LED and Bright 65,536 (16-bit) Colors
- Downloadable Trend Information via USB Host Port or Network Device
- 128MB Flash Memory, 64MB DRAM
- Built-in Ethernet Port 10/100 Base-T (RJ45)
- Supports over 100 Communication Protocols including Ethernet IP, and Modbus TCP/IP
- BACnet IP communication available (**Option "N"**)
- Built-in VNC server allowing remote monitoring of live graphics through standard browser, smart phones & mobile devices
- Share data between HMI and Building Management systems

**Automatic Purge Control**

- Each pump intake is equipped with an automatic purge valve and automatic isolation valve
- Minimum run and purge cycle are controlled via SIGNAL 1 purge control function
- Selection of automatic purge, manual purge, or purge off
- 15 minute purge cycle per pump
- Can be set to exit purge if vacuum falls below a setting

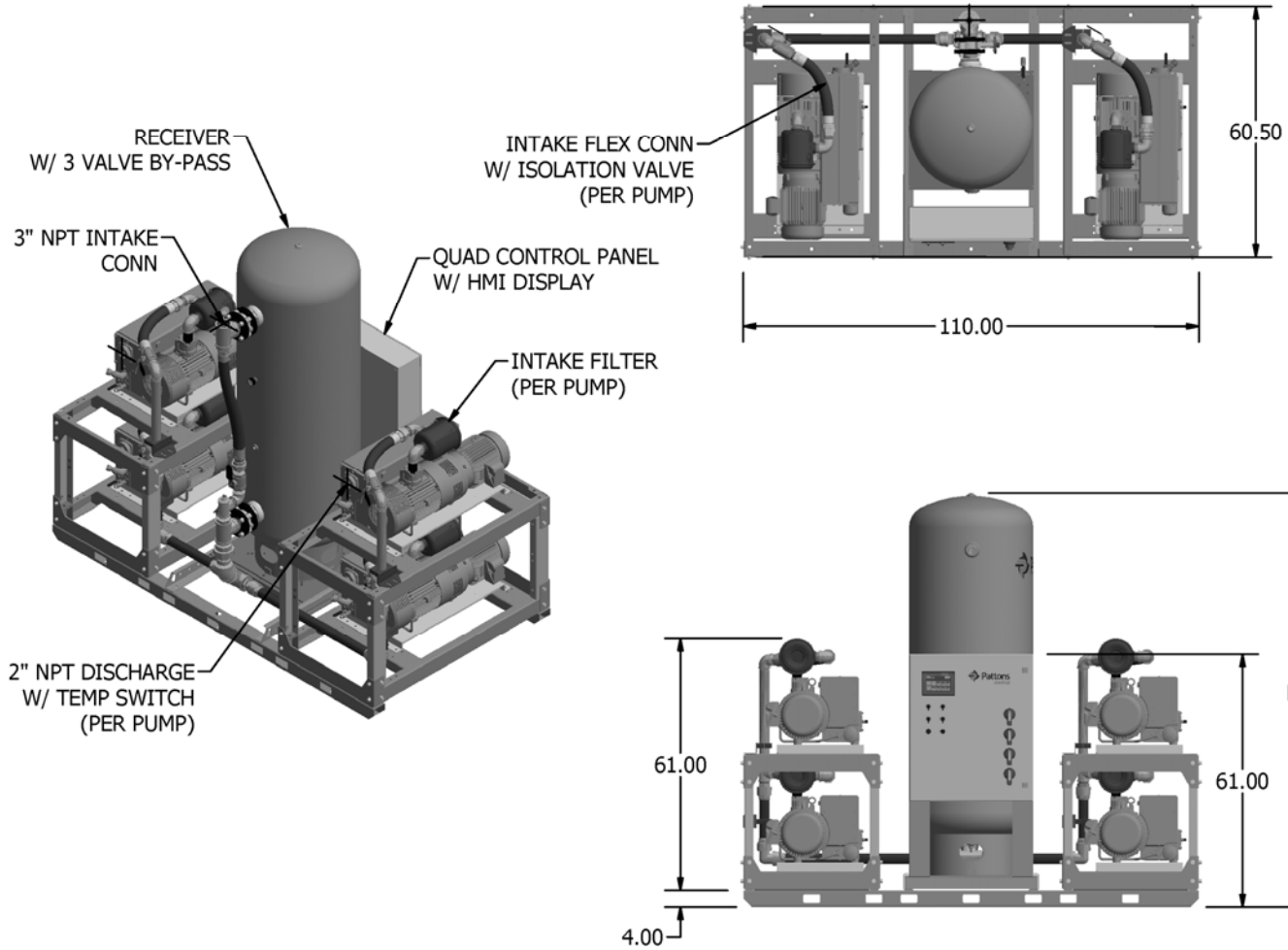

Quadruplex Lubricated Rotary Vane Lab Vacuum Package Specification

Model Number	HP	Capacity @19" Hg <sup>2</sup>		Package BTU/HR <sup>3</sup>	Noise Level <sup>4</sup>	System FLA			Receiver Size (gallons)	H (inches)	Package Weight (pounds)
		Pump (SCFM)	System (SCFM)			208V (A)	230 (B)	460V (C)			
73L-43-154(A/B/C)	15	111	444	153,000	89	165	152	76	200	88	8,144
73L-43-155(A/B/C)									240	100	8,282

Notes:

- <sup>1</sup> Normal Operating conditions at a maximum ambient of 105° F. Consult factory for higher ambient conditions.
- <sup>2</sup> Capacities are shown with all pumps running.
- <sup>3</sup> Package BTU/HR are shown with all pumps running.
- <sup>4</sup> Noise levels are shown in dB(A) and reflect all vacuum modules running.

Statement of Warranty

Patton's Medical warrants all Lab Air packages, to be free of defects in material and workmanship under normal use for a period not to exceed thirty (30) months from date of shipment, or twenty-four (24) months from date of start-up.